

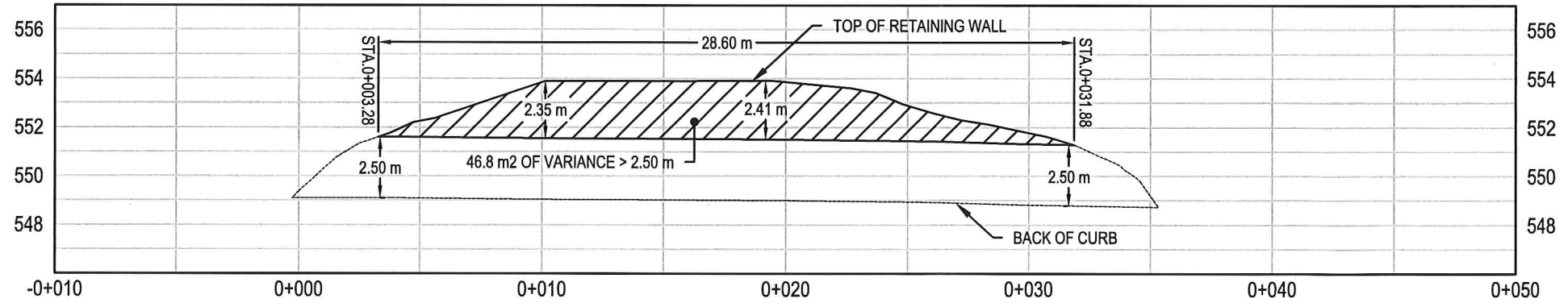

RETAINING WALL LOCATION

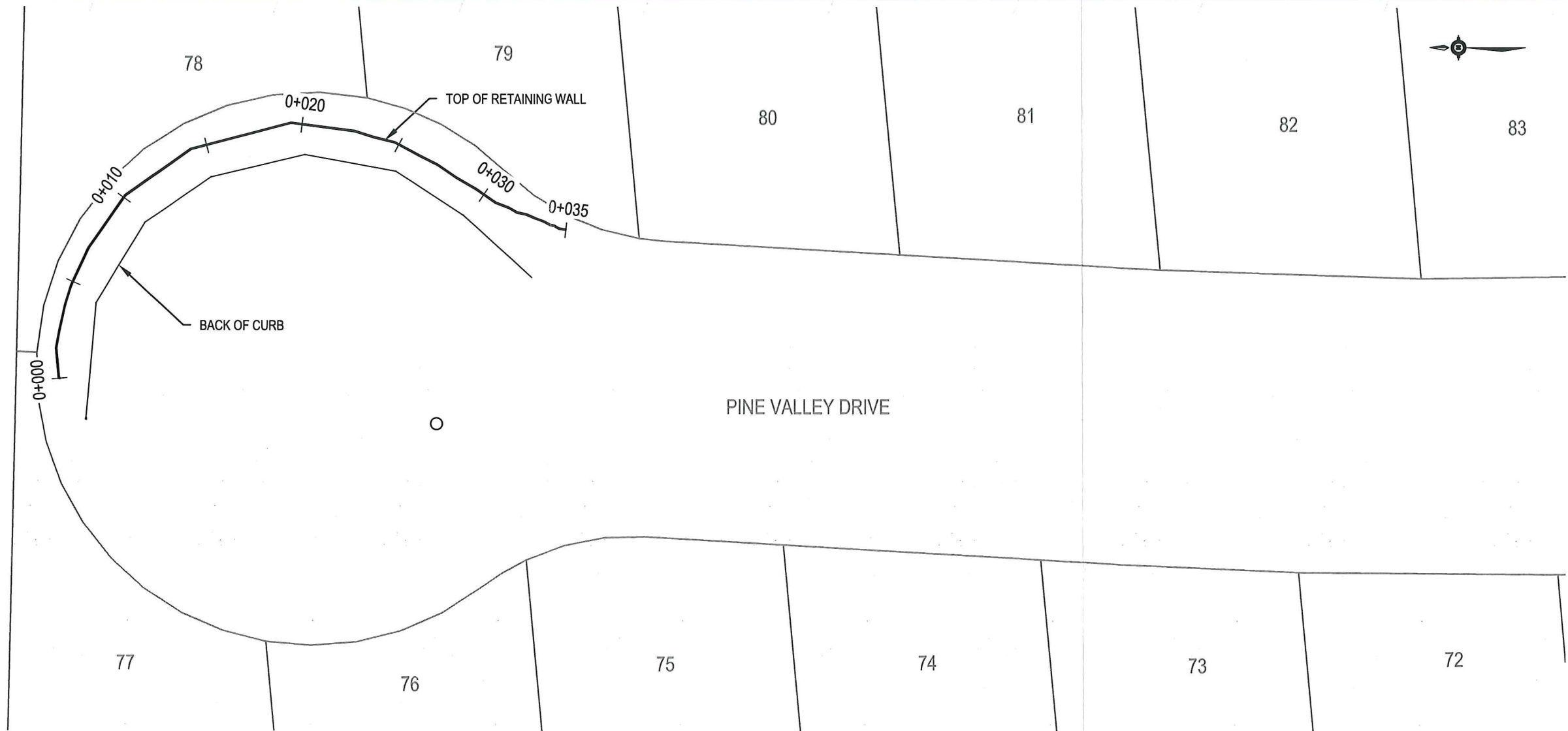

**LEGEND**  
 AREA OF VARIANCE

**NOTES**

- BASED ON CSV FILE PINEVALLEYS DR.CSV PROVIDED BY SUTTIN & CEIDAR CONSULTING GROUP JULY 2019.
- ORIGINAL SURVEY DATA IN AN ARBITRARY COORDINATE SYSTEM. SURVEY POINTS ALIGNED AND ROTATED AROUND A SURVEYED MANHOLE AND CADASTRAL FROM RDCO WEBSITE.
- 1M CONTOUR INTERVAL SHOWN.

*[Signature]*  
 7. Aug 2019.

**ISSUED FOR USE**

CLIENT <b>SUNSET TWO PROPERTIES</b>	<b>SUNSET RANCH - PINE VALLEY DRIVE - KELOWNA, BC</b>			
	<b>PLAN - PROFILE RETAINING WALL VARIANCE</b>			
PROJECT NO. KGE003346-01	DWN SM	CKD SB	REV 0	Figure 1
OFFICE KEL	DATE JULY 31, 2019			



C:\Users\stan.matsuda\Documents\PINEVALLEYDRIVE.dwg [FIGURE 1] August 06, 2019 - 1:50:02 pm (BY: MATSUDA, STAN)

